

MULTI-FUNCTIONAL COMPUTER TABLE

ASSEMBLY INSTRUCTION



IMPORTANT: Surfaces must be cleaned with a solution of a smooth soap and water, then cleared with a dry towel. Do not use solvents over surfaces or structural tubes.

MODEL RTA - S06

In case of assistance, please contact us: Toll Free Customer Service: 1-866-782-8262 or e-mail our Customer Service: warranty@rtaproducts.com

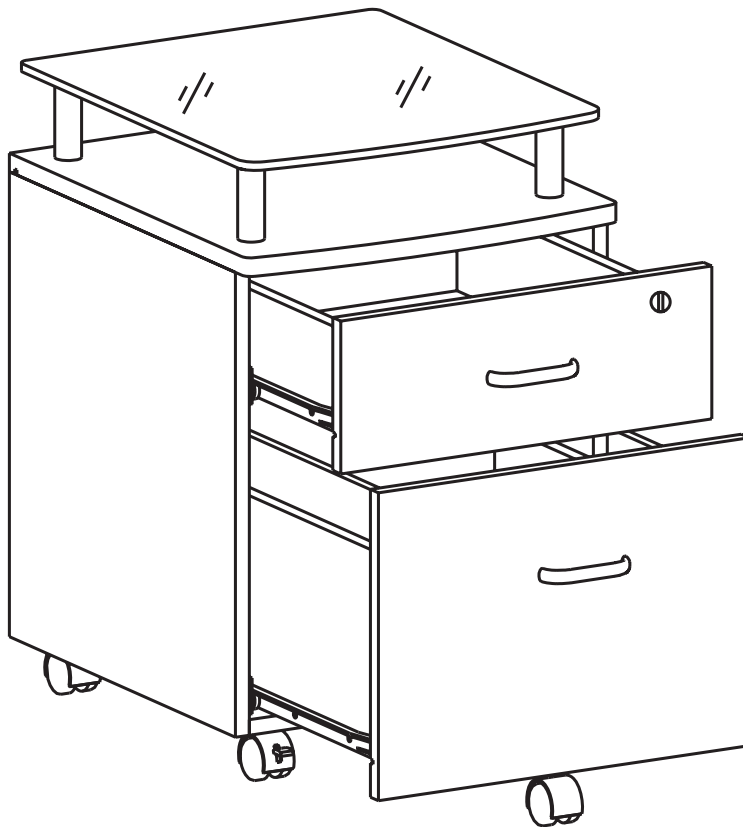







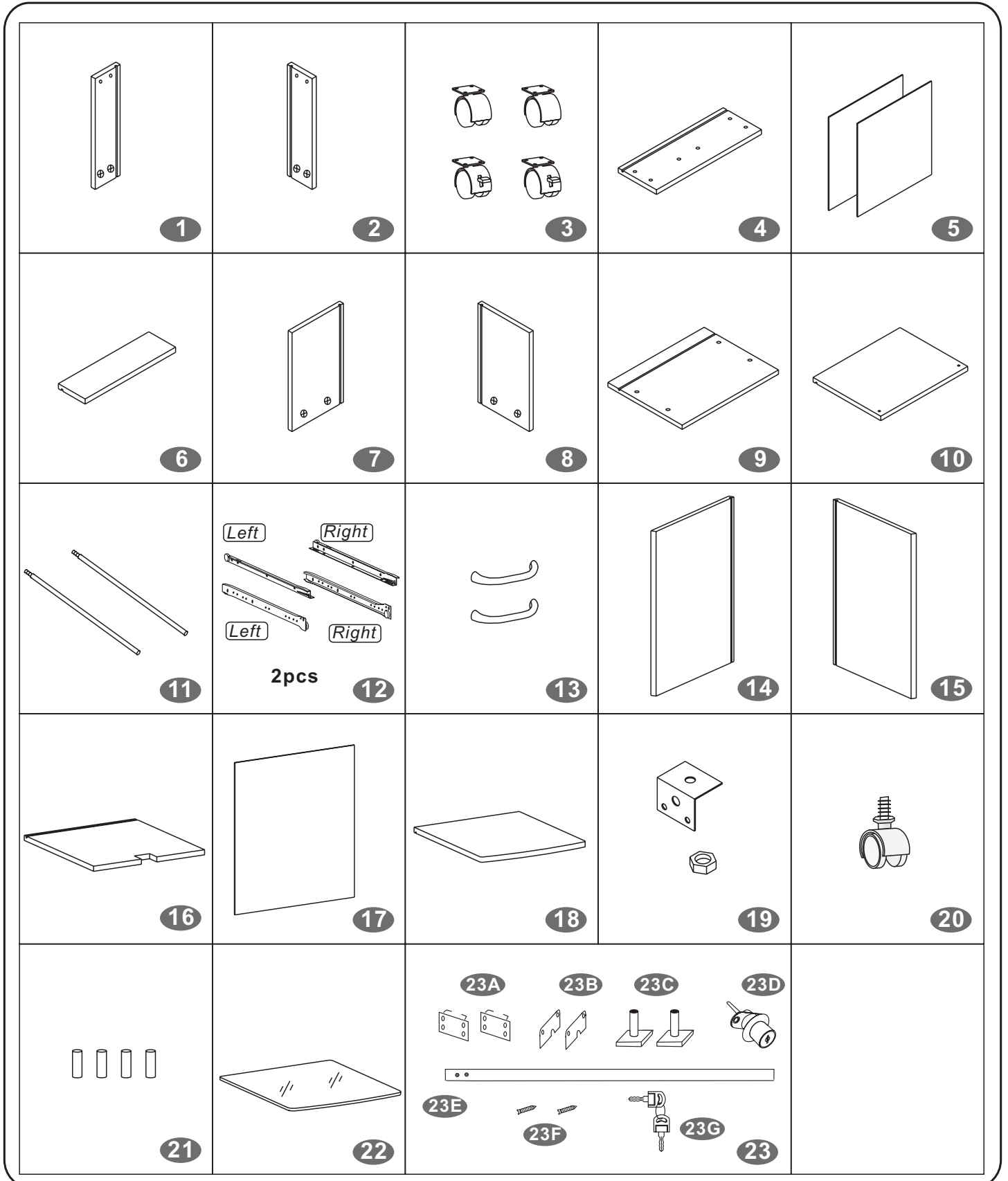

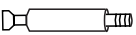
MODEL RTA-S06

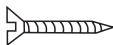

Thanks for purchasing one of our products, please read carefully the assembly instructions before the installation (Attention: Do not tighten the screws before all screws are in place).

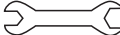

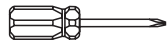
PART	QTY.	ITEM		PART	QTY.	ITEM	
A	16	6X40 MM		F	1	6X12 MM	
B	8	4X30 MM		G	4	6X20 MM	
C	30	3X15 MM		H	4	6X25 MM	
D	4	4X20 MM			1		
E	18	4X14 MM			1		

6x40mm bolt installation as below:

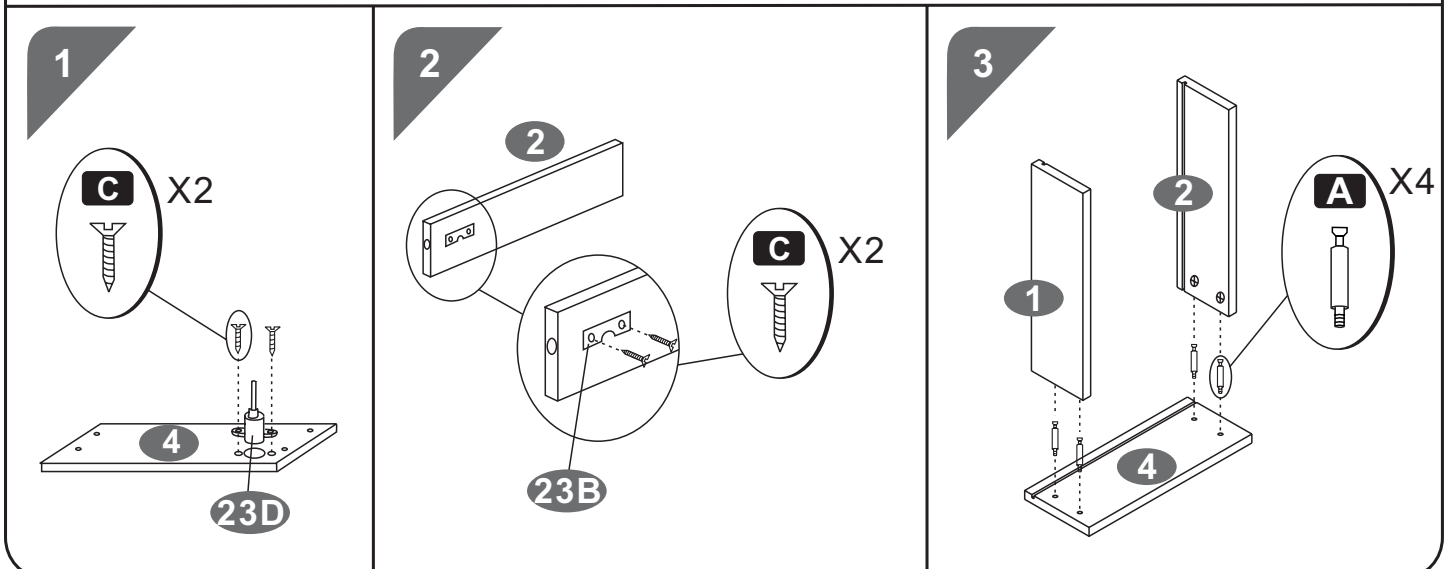
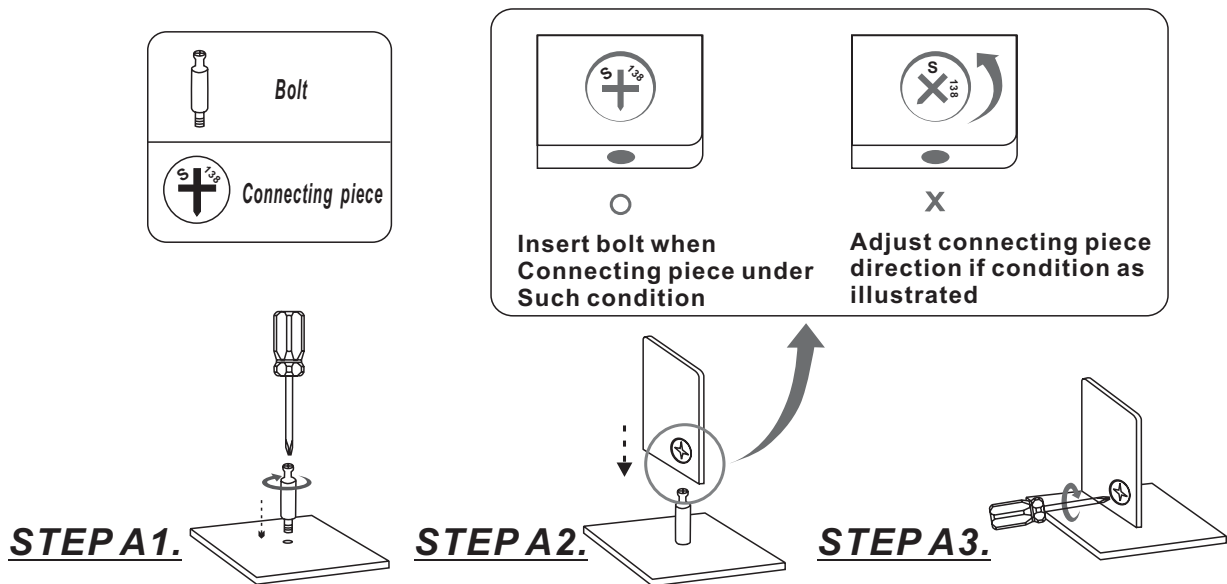

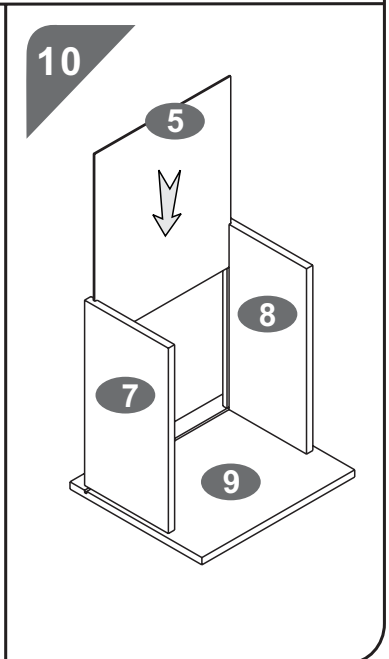
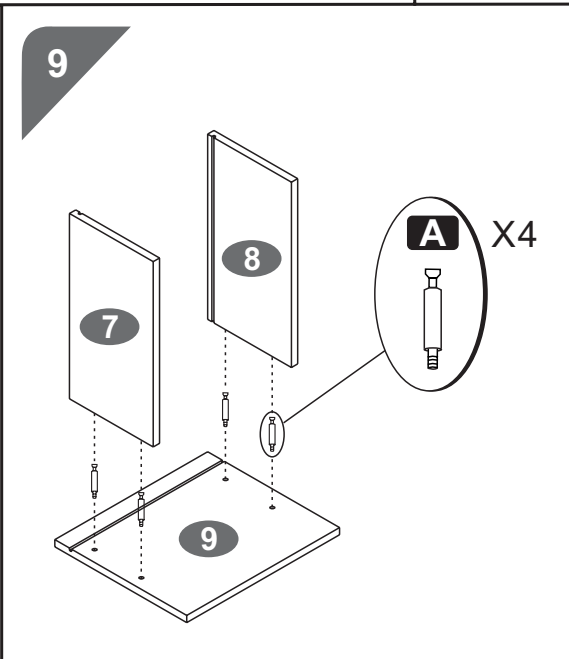
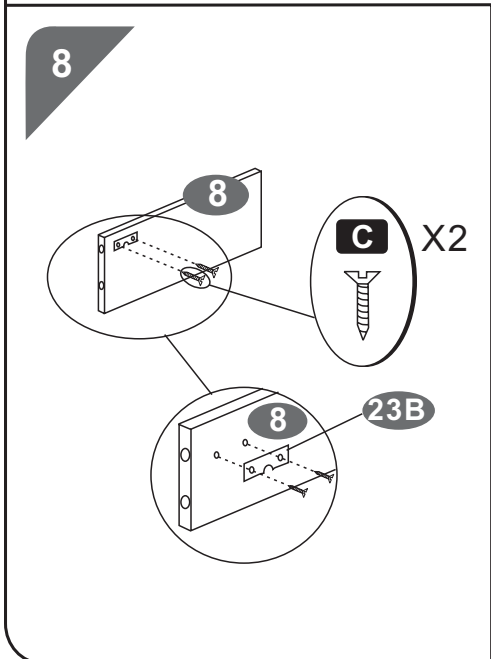
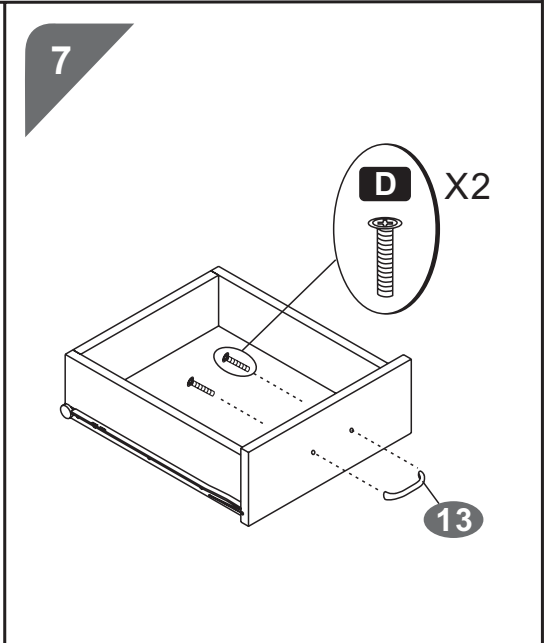
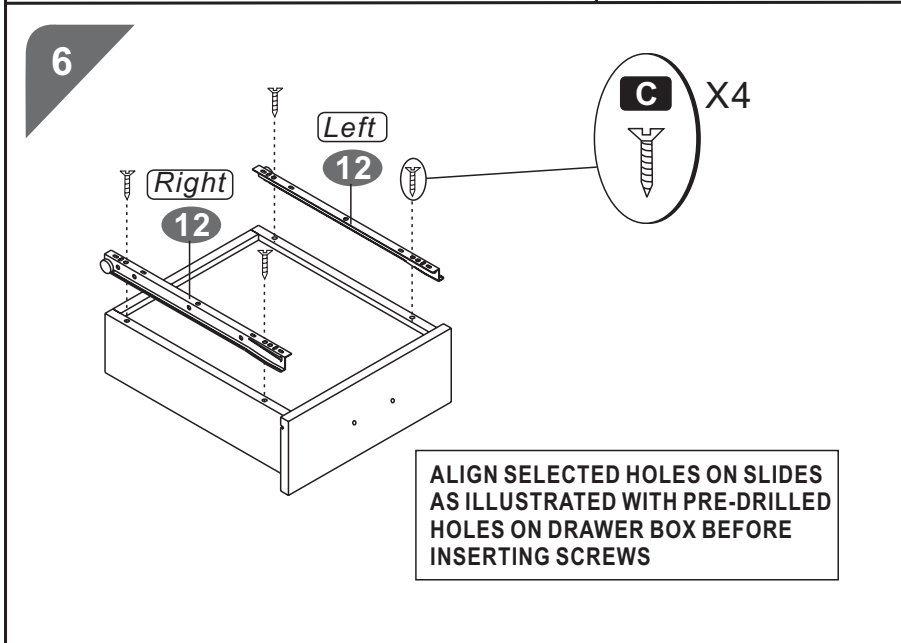
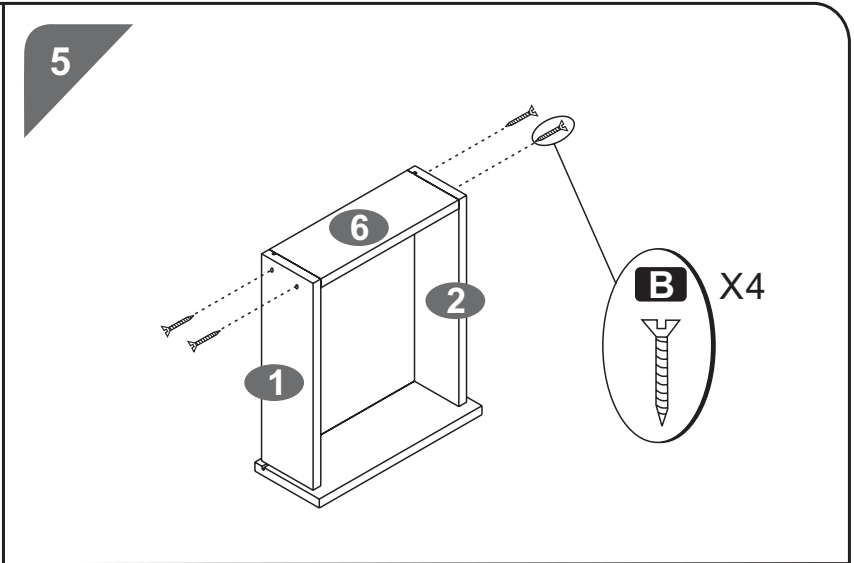
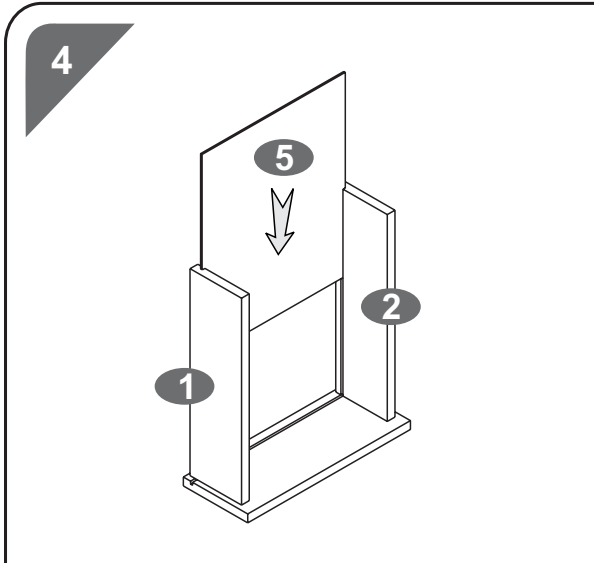

11

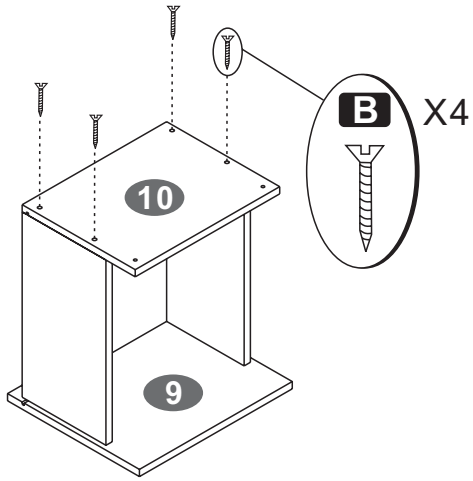

12

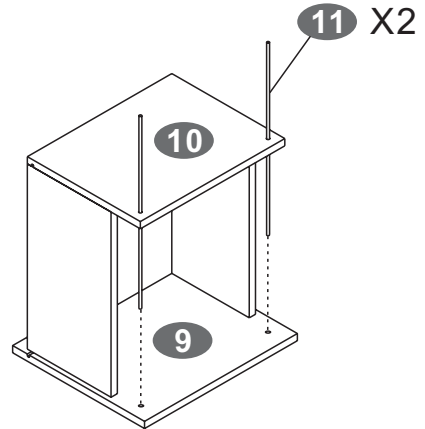

13

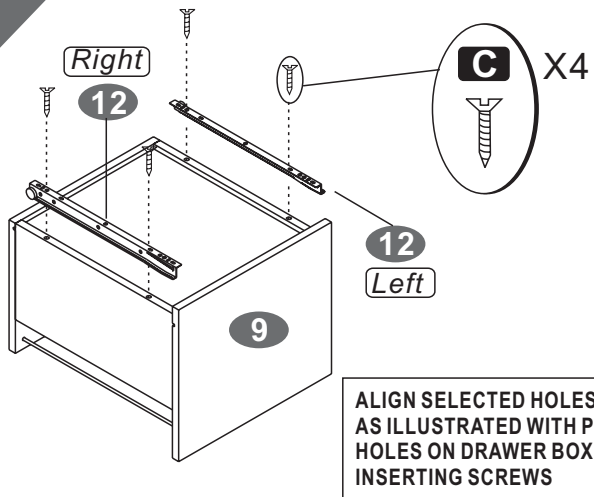

14

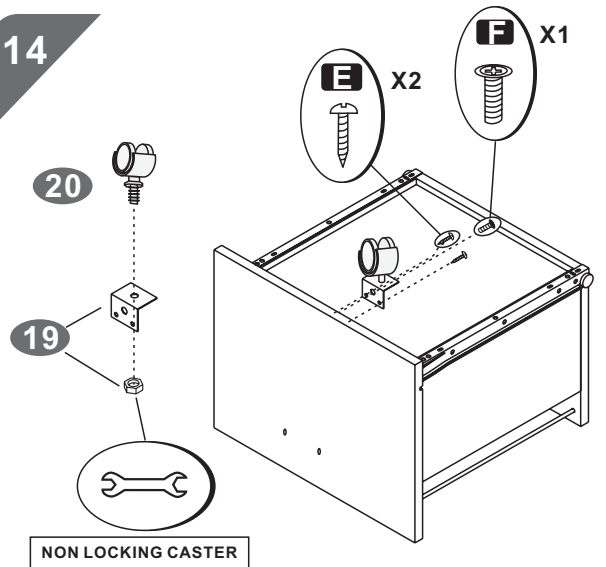

15

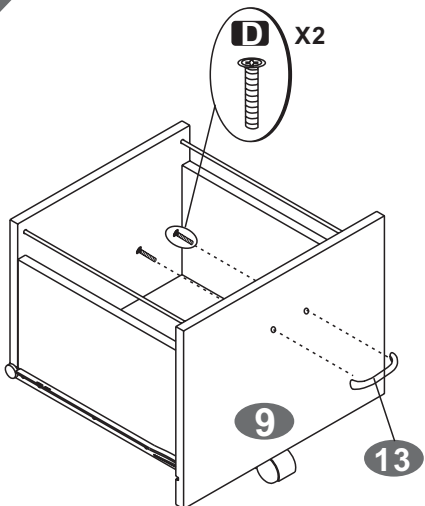

16

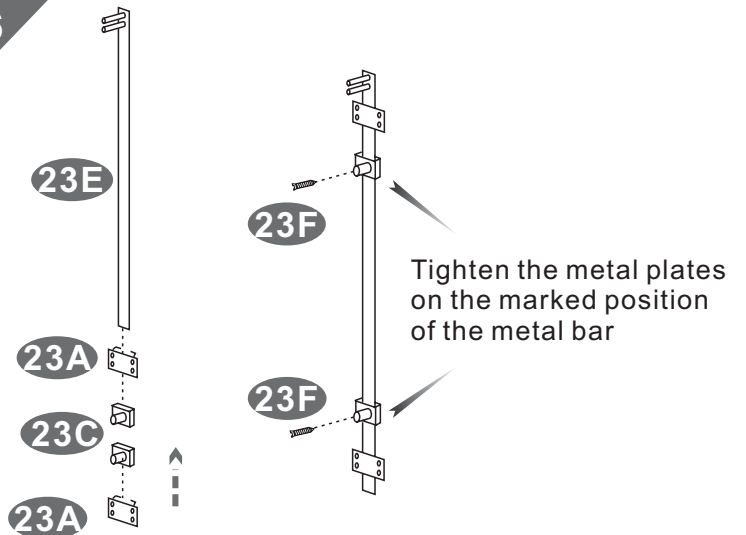

17

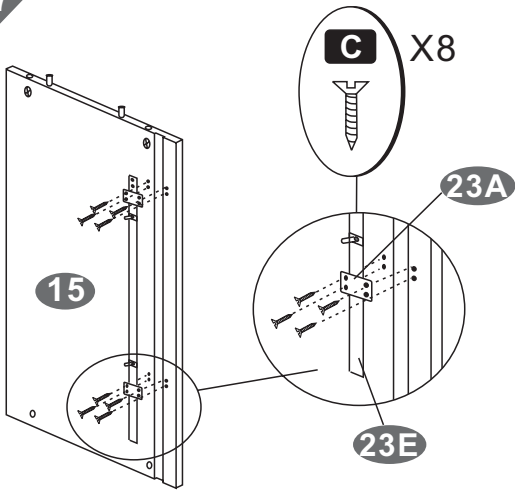

18

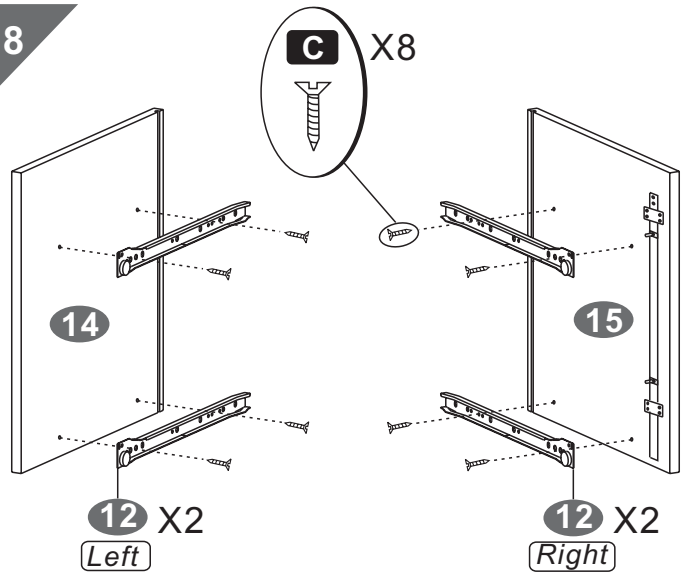

19

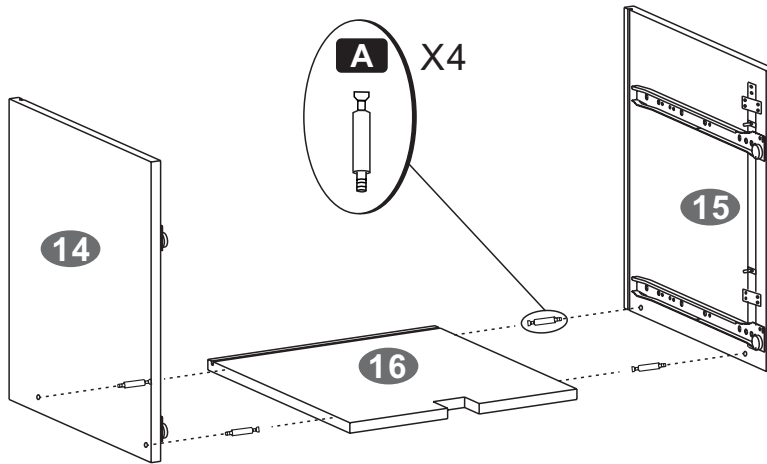

20

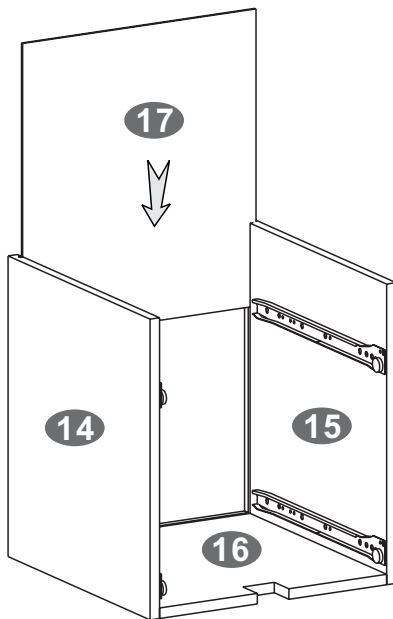

21

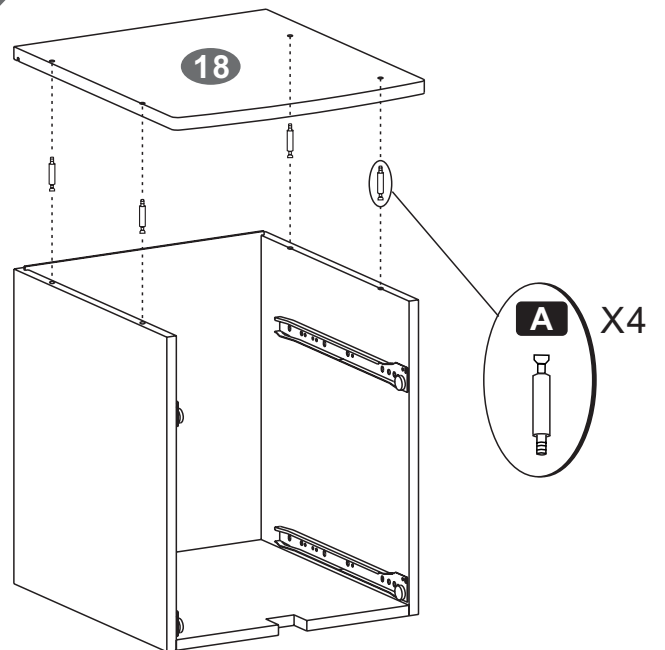

22

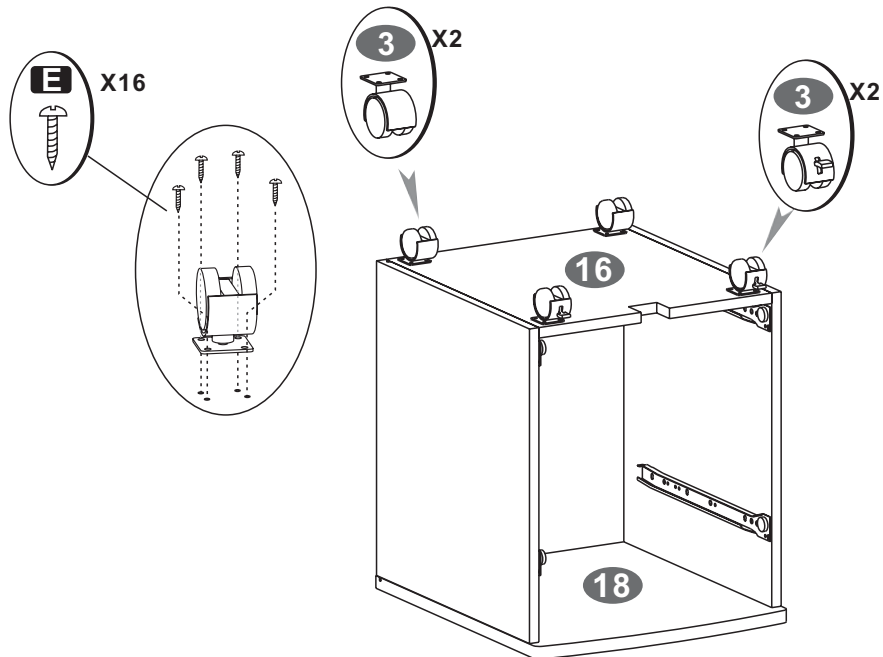

23

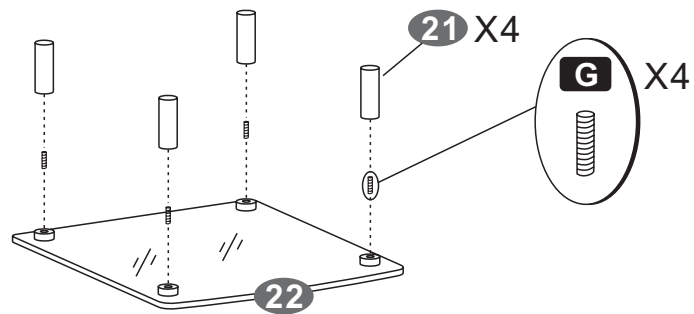

24

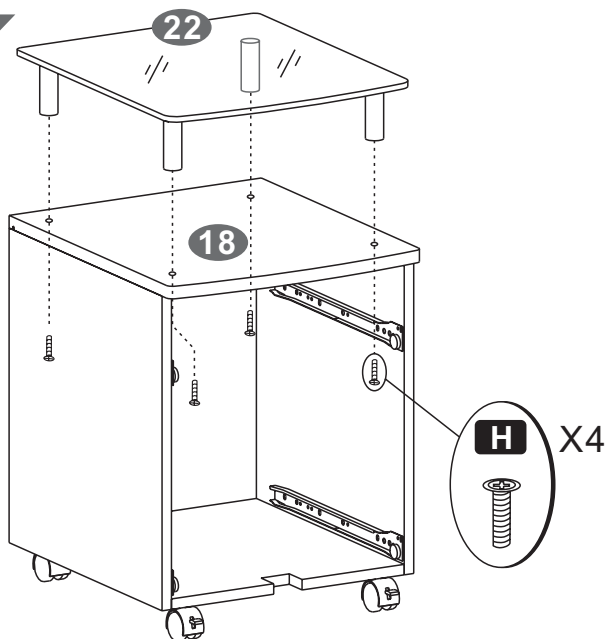

25

