

MULTI-FUNCTIONAL COMPUTER TABLE

ASSEMBLY INSTRUCTION

TECHNI
MOBILI

IMPORTANT: Surfaces must be cleaned with a solution of a smooth soap and water, then cleared with a dry towel. Do not use solvents over surfaces or structural tubes.

MODEL RTA - 5009

In case of assistance, please contact us: Toll Free Customer Service:
1-866-782-8262 or e-mail our Customer Service: info@rtaproducts.com

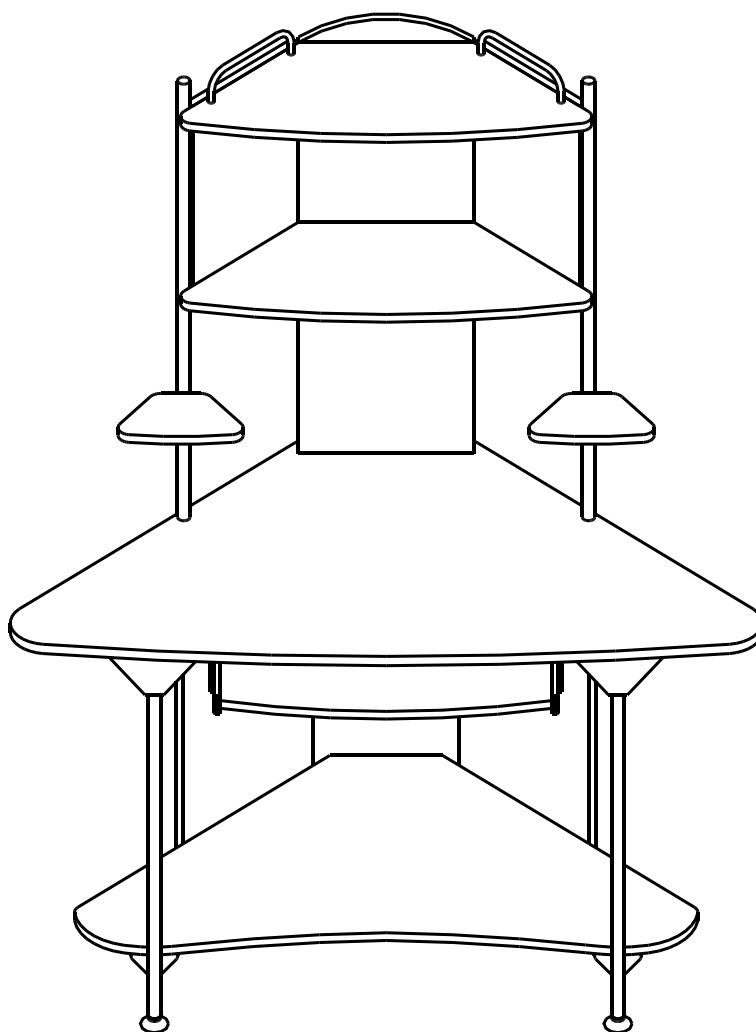

MODEL RTA-5009









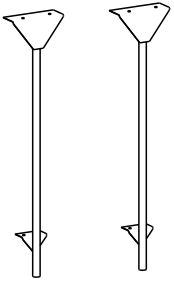
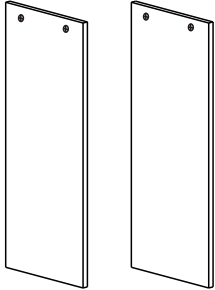

RTA
PRODUCTS • LLC

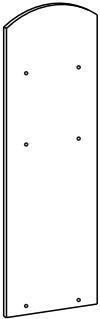

Steps:

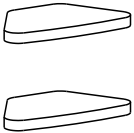

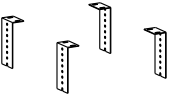
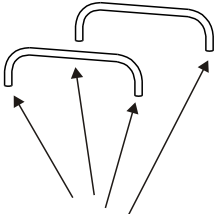
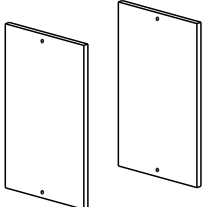
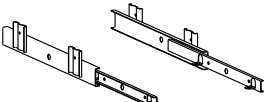

Note: When you insert the Clam Bolts E in the following steps, make sure the screw inside the hole is aligned and after is inserted tight the corresponding screw in the inside face of the panel to secure the bolt in its place.

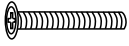
1. Use screws F to fix Slider Holders (13A) to the back side of Tabletop (5).
2. Use screws G to fix Slider (13B) to the Slider Holders (13A).
3. Use screws C to assemble Legs (1) to the back side of the Tabletop (5).
4. Insert Studs (3) to the Legs (1) and tight them.
5. Use Bolt E to assemble Side Panels (2) to the Back Side of The Tabletop(5).
6. Use screws A & C to fix the Bottom Panel (4) to the Side Panels (2) and the Legs (1).
7. Use screws F to assemble Keyboard Panel (12) with Sliders (13B).
8. Use screws A to assemble Back Panel (6) with the Tabletop (5), while screws D for Left & right Support Tubes (7 & 8).
9. Use screws A to fix the Horizontal Panel (10) with the Left & Right Support Tubes (7&8) and the Back Panel(6).
10. Use screws A to assemble the Top Panel (11) with the Support Tubes (7 & 8) and the Back Panel (6).
11. Use screws A to assemble the Upper Side Panels (15) to Panels (10&11).
12. Use screws B to fix the Protector Tubes (14) to the Top Panel (11).
13. Use screws C to fix the Auxiliary Panels (9) to the Support Tubes (7 & 8).
14. Tight well all screws and enjoy your unit.

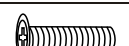
Thanks for purchasing one of our products, please read carefully the assembly instructions before the installation (Attention: Do not tighten the screws before all screws are in place).

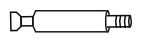
 <p>Legs 1</p>	 <p>Side Panel 2</p>	 <p>Studs 3</p>	 <p>Bottom Panel 4</p>
 <p>Tabletop 5</p>	 <p>Back Panel 6</p>	 <p>Left Support tube 7</p> <p>Screws D X1</p>	 <p>Right Support tube 8</p> <p>Screws D X1</p>
 <p>Auxiliary Panel 9</p>	 <p>Horizontal Panel 10</p>	 <p>Top Panel 11</p>	 <p>Keyboard Panel 12</p>
 <p>Slider Holder 13A</p>	 <p>Protector Tubes 14</p> <p>Screws B X4</p>	 <p>Upper Side Panels 15</p>	
 <p>Sliders 13B</p>			

PART	QTY.	ITEM	
A	18	6X50MM	
B	4	6X25 MM	
C	12	6X12 MM	
D	2	8X35 MM	

PART	QTY.	ITEM	
E	4	6X40 MM	
F	12	4X14 MM	
G	4	4X4 MM	
	1		

Remarks: 2 PCS of Screws D & 4PCS of Screws B have been assembled into the tubes

6X40MM BOLT INSTALL METHOD AS FOLLOW:

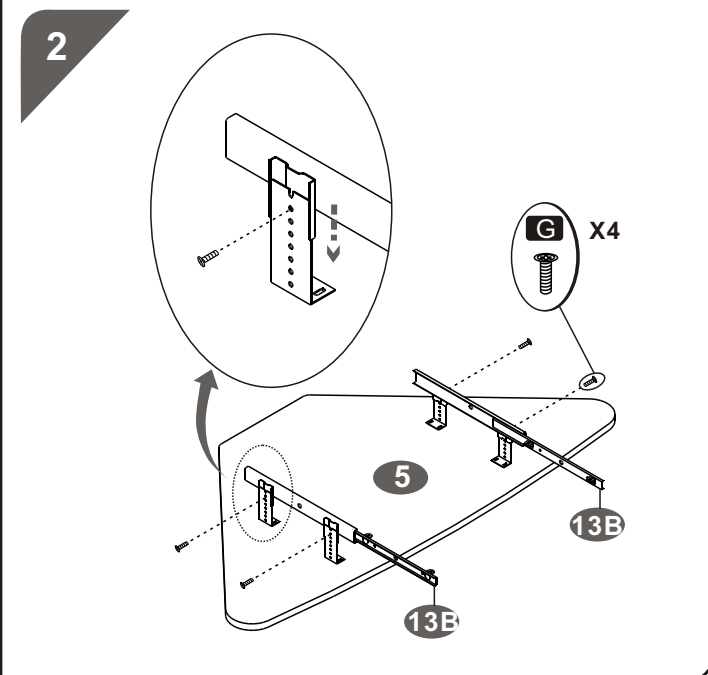
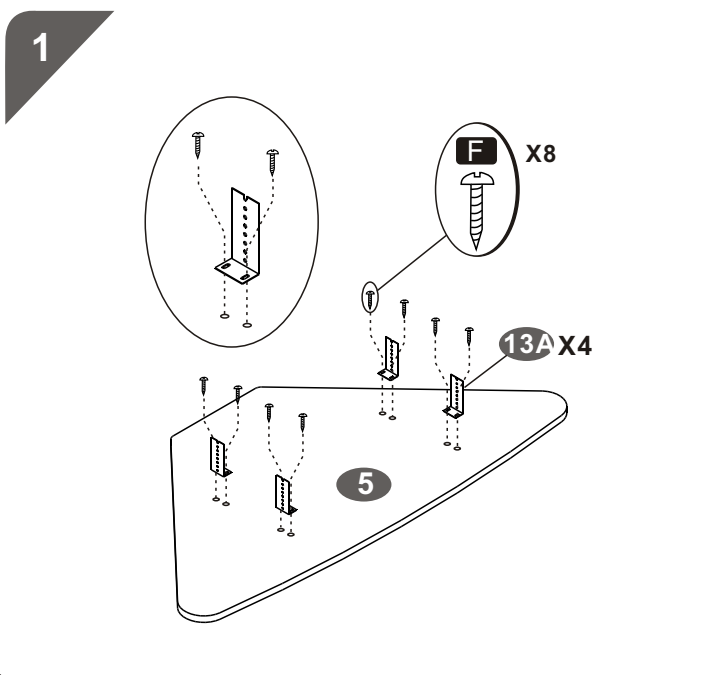
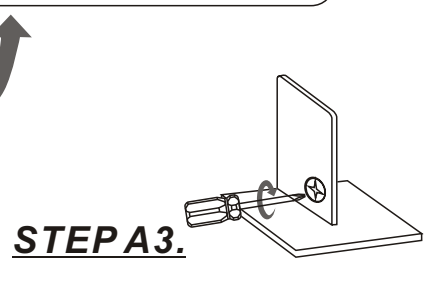
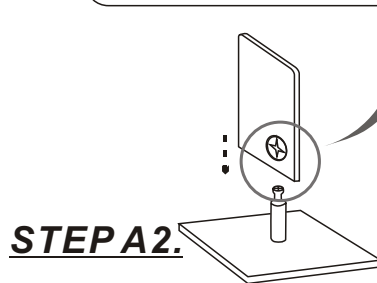
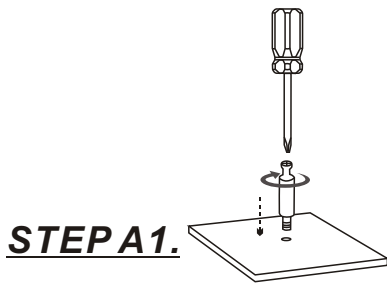
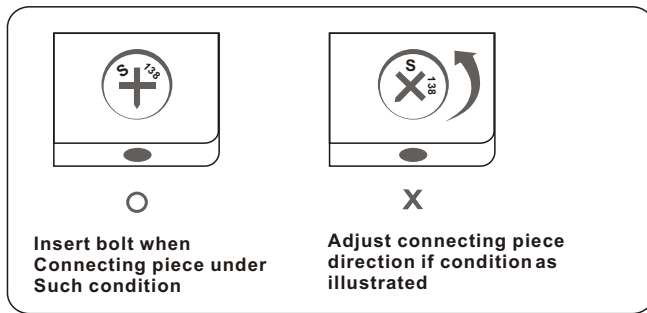
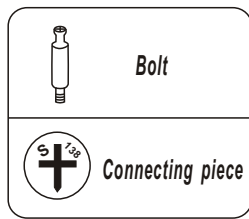

3

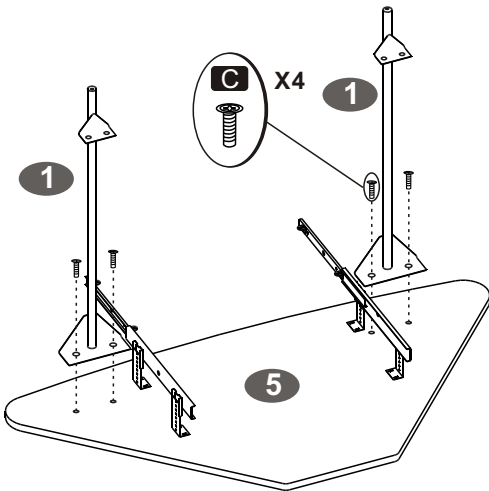

4

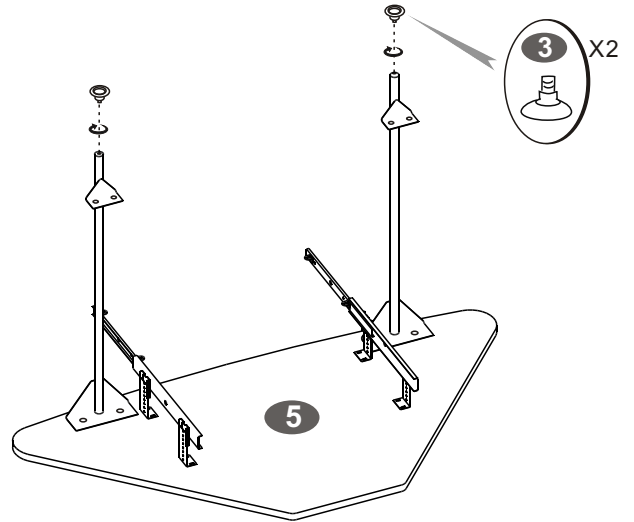

5

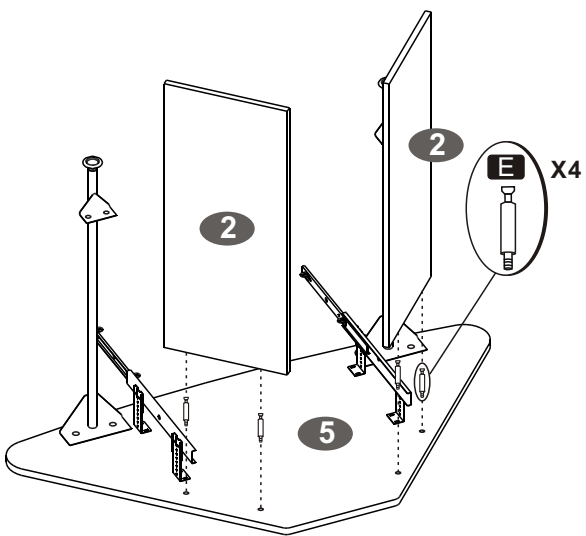

Assembly Instruction same as STEPA1, A2, A3

6

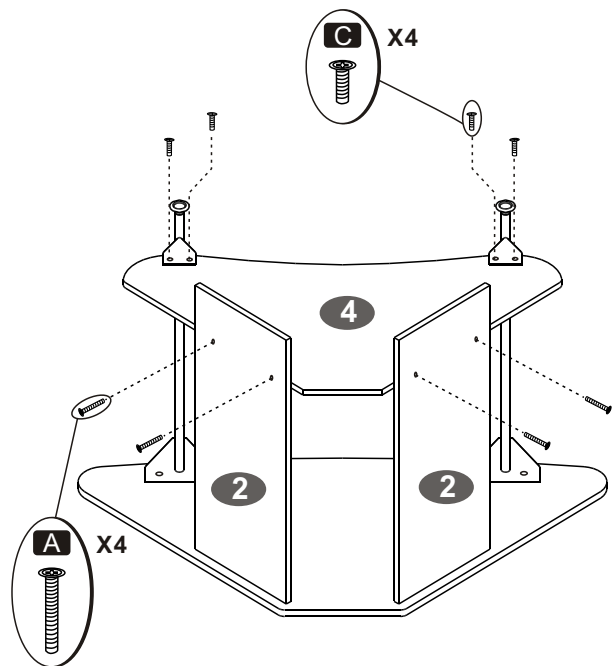

7

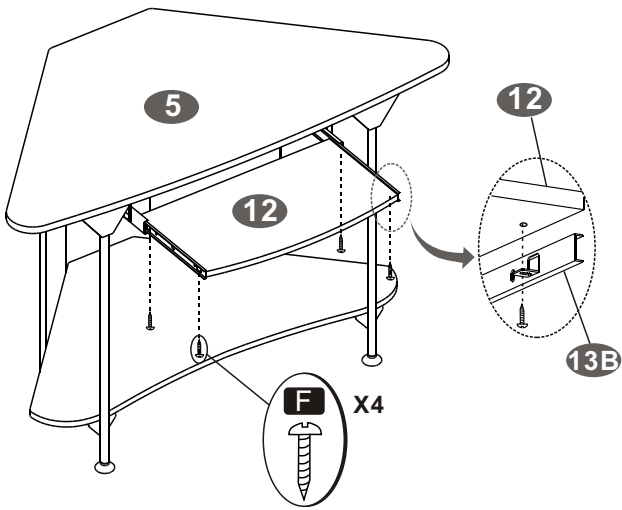

8

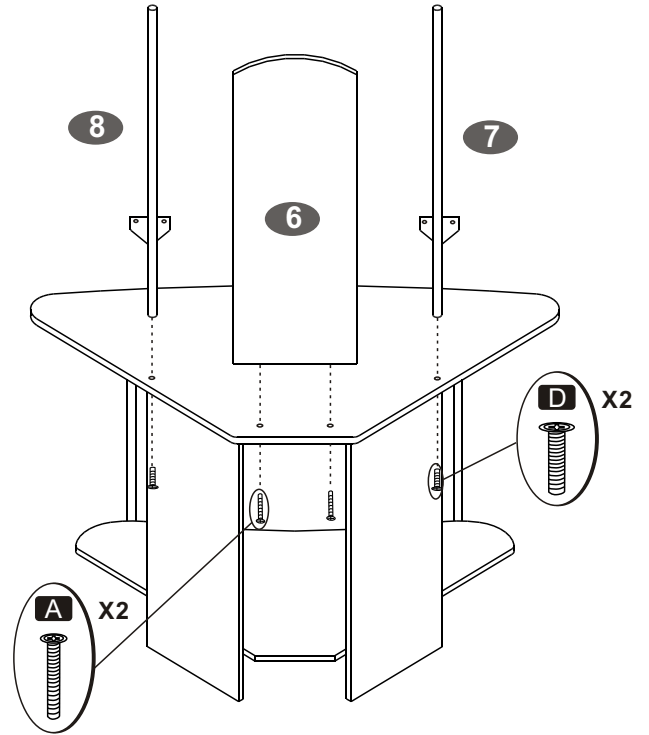

9

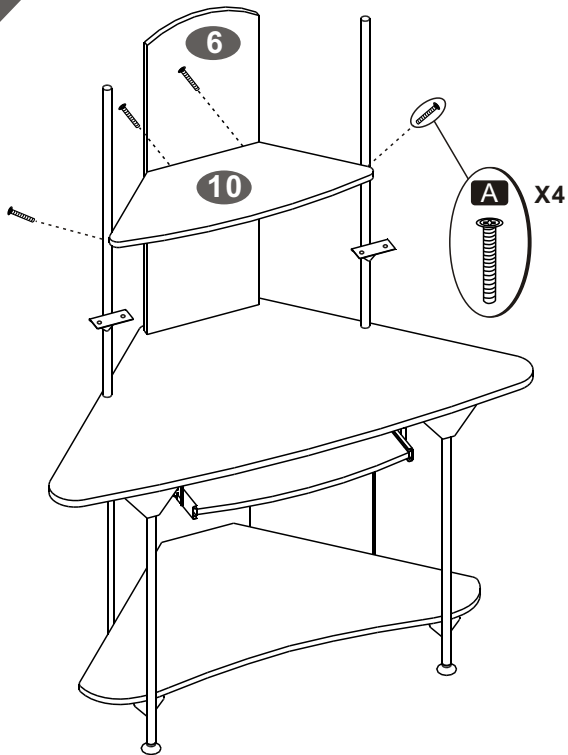

10

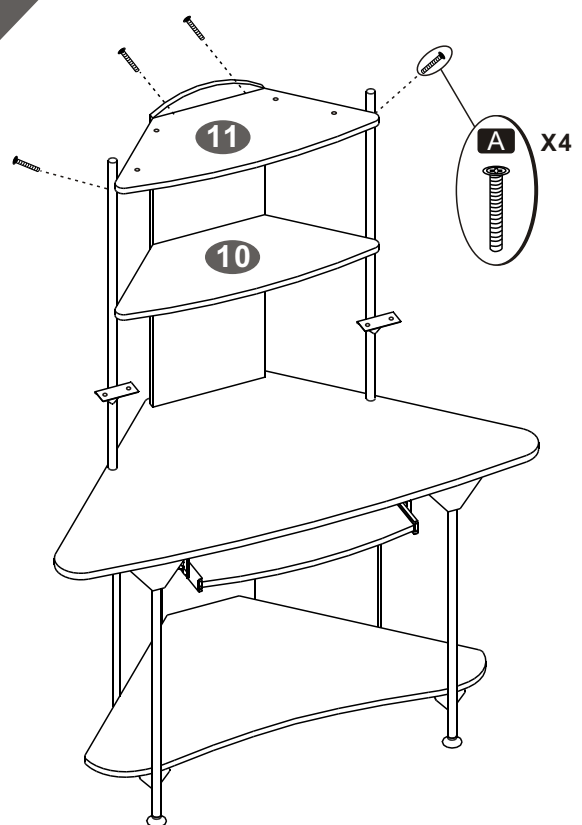

11

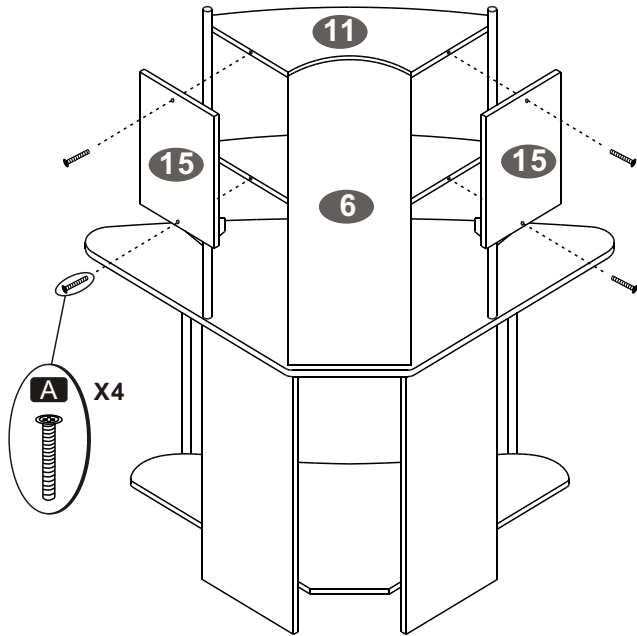

12

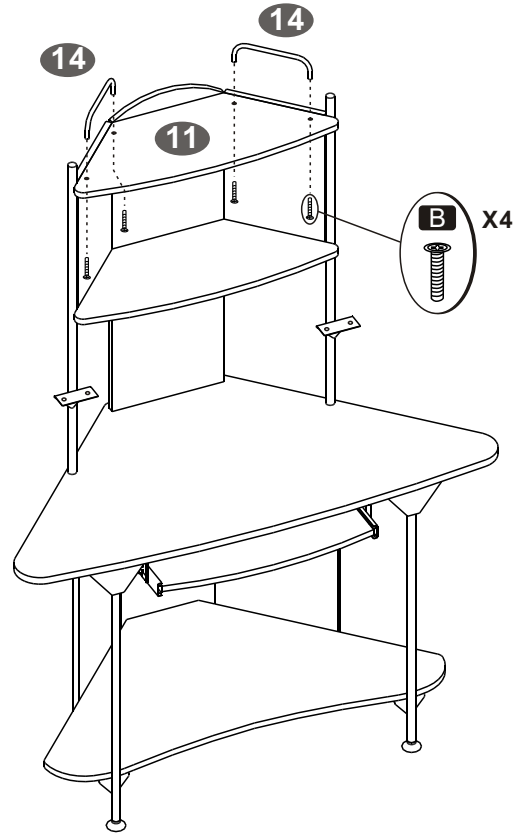

13

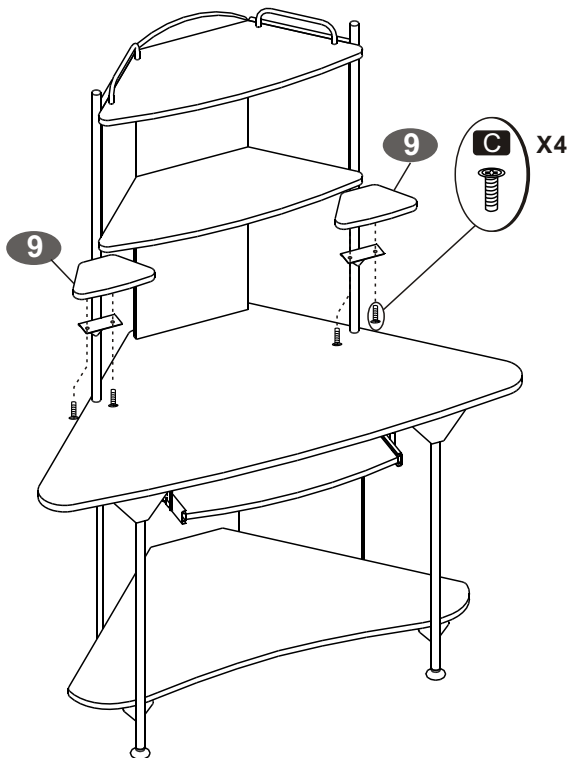

14

